

## HZ-43 / IZ-43 (1E40F-5 GASOLINE ENGINE)

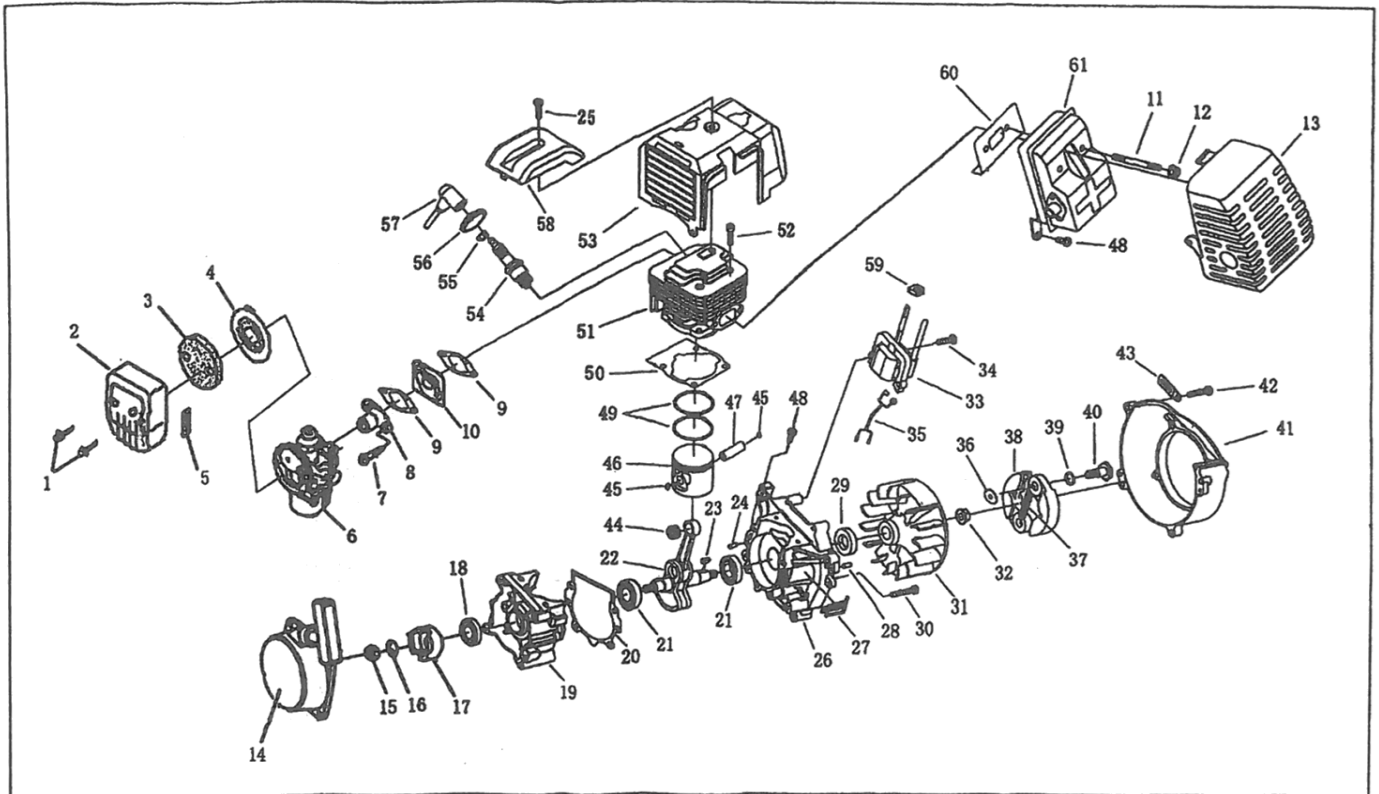

No.	Part Name	Qty	No.	Part Name	Qty	No.	Part Name	Qty
1	Screw M4 x 25	2	22	Crank Shaft	1	43	Stand	1
2	Cleaner Outside Cover	1	23	Key 3 x 5 x 13	1	44	Bearing	1
3	Filter Net	1	24	Pin B4 x 10	2	45	Ring	2
4	Cleaner Inside Cover	1	25	Screw M5 x 25	1	46	Piston	1
5	Label	1	26	Crank Cover	1	47	Piston Pin	1
6	Carburetor	1	27	Gurde Cover	1	48	Bolt M5 x 12	1
7	Screw M5 x 20	2	28	Pin B4 x 10	2	49	Piston Ring	2
8	Pipe	1	29	Oil-seal	1	50	Gasket	1
9	Gasket	2	30	Screw M5 x 30	4	51	Cylinder	1
10	Insulator	1	31	Magneto Rotor	1	52	Screw M5 x 20	4
11	Bolt	2	32	Nut M8	1	53	Guide Cover Ass'y	1
12	Nut	2	33	Ignition Coil	1	54	Spark Plug	1
13	Muffler Cover	1	34	Bolt M5 x 20	2	55	Spring	1
14	Starter Assy	1	35	Cord Comp.	1	56	Plug Cap	1
15	Washer	1	36	Washer B	2	57	Cap	1
16	Nut	1	37	Spring	1	58	Cover	1
17	Ratchet	1	38	Expander	2	59	Plug	1
18	Oil-seal	1	39	Washer	2	60	Gasket	1
19	Crank Case	1	40	Screw Pin	2	61	Muffler	1
20	Gasket	1	41	Fan Cover	1			
21	Bearing 6202/P5	2	42	Bolt M5 x 12	4			