

# MOVABLE VENTILATOR

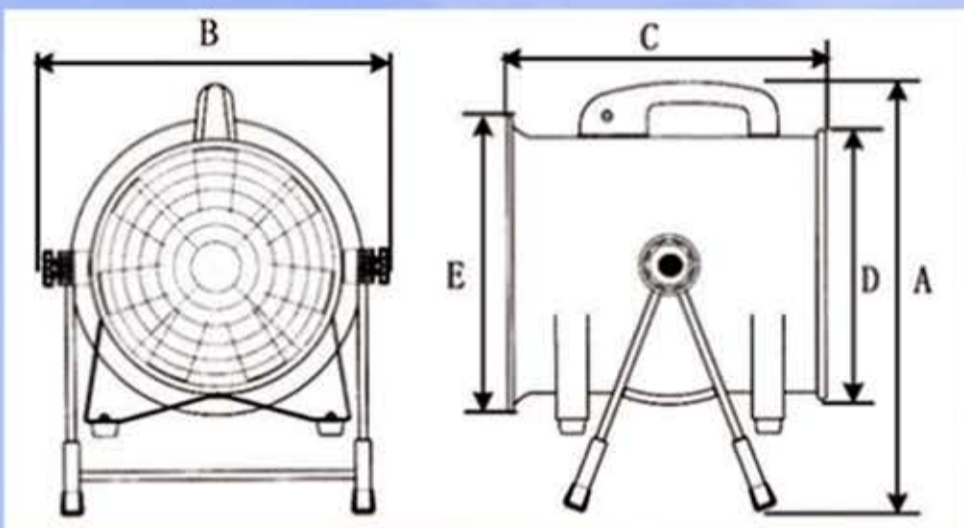

## Features:

- Energy-efficient low voltage with energy saving & low noise
- Uniquely designed, scientifically structured and characterized with smooth operation & high efficiency



Model	Size	A(mm)	B(mm)	C(mm)	D(mm)	E(mm)
SHT - 30A	(12")	360	320	298	210	260
SHT - 40	(16")	520	480	450	430	470
SHT - 45	(18")	590	530	495	473	520
SHT - 50	(20")	625	590	495	525	580
SHT - 60/60B	(24")	838	680	495	625	670

Model	Size (mm)	Power (w/ph/v)	Speed (rpm)	Air Volume (m <sup>3</sup> /min)	Max. Pressure	Num. Blade	Weight (kg)
SHT - 30A	300(12")	520/1/230	2800	60	345	7	11
SHT - 40	400(16")	1100/1/230	2800	96	700	7	27
SHT - 45	450(18")	1500/1/230	2800	162	972	7	29
SHT - 50	500(20")	1800/1/230	2800	200	1050	6	36
SHT - 60B	600(24")	2000/1/230	1400	220	1050	6	53
SHT - 60	600(24")	2000/3/415	1400	220	1050	6	53
SHT - 70	700(28")	3000/3/415	1400	408	350	4	60

