

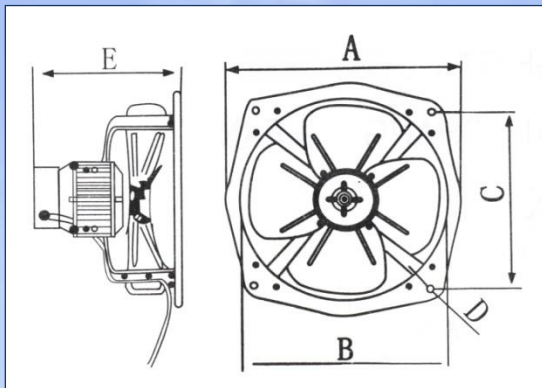

INDUSTRIAL EXHAUST FAN

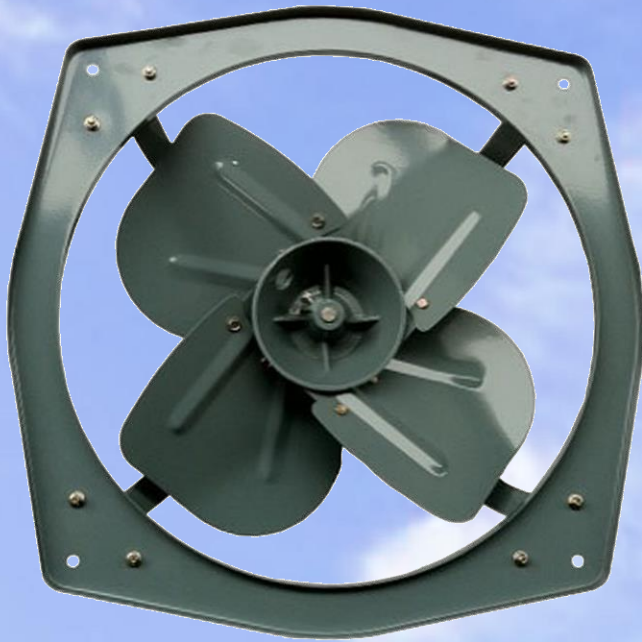

Size (mm)	A (mm)	B (mm)	C (mm)	D (mm)	E (mm)
300 (12")	390	Ø325	308	Ø8.5	235
400 (16")	483	Ø417	367	Ø8.5	255
450 (18")	558	Ø476	435	Ø10.5	305
600 (24")	700	Ø623	585	Ø12.0	370

Model	Size (mm)	Phase	Voltage (v)	Frequency (Hz)	Power (w)	Speed (rpm)	Air Flow (m ³ /min)
GH-30	300 (12")	1	220~240	50	100	1400	30
GH-40	400 (16")	1	220~240	50	165	1400	48
GH-45	450 (18")	1	220~240	50	230	1400	82
GH-60	600 (24")	1	220~240	50	700	1400	196
GTH-60	600 (24")	3	415	50	700	1400	196

