

ELECTRIC CHAIN HOIST

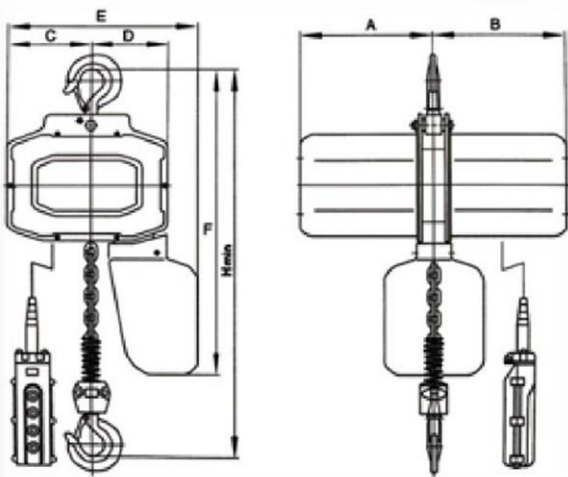

Model	Main Dimensions (mm)					
	A	B	C	D	E	H
HHW-B						
B05	245	245	158	142	350	500
B10	245	245	158	142	350	520
B20	245	245	124	176	350	630
B30	245	245	124	176	350	710

MODEL	HHW-B				
	B05	B10	B20	B30	
Capacity	(ton)	0.5	1	2	3
Lifting Speed	(m/min)	7	6	3	2
Motor Power	(kw)	0.8	1.2	1.2	1.2
Insulation Grade		F			
Power Supply		1Ph / 220V / 50Hz			
Load Chain	(mm)	7.1 x 21			
No. of Falls		1	1	2	3
Running Test Load	(T)	0.625	1.25	2.5	2.75
Net Weight	(kg)	55	60	65	70

